

WORKSHOP 3

Fluid Advection Thermal Analysis

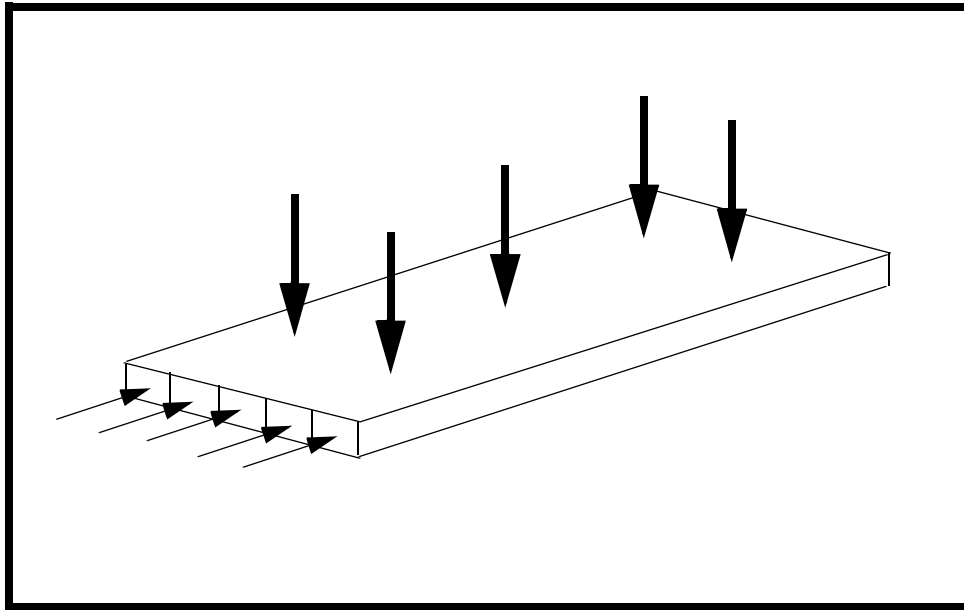

Objectives:

- Create a geometric representation of a rectangular duct.
- Apply appropriate convection and advection loads to model the airflow through the duct of this heat exchanger.
- Add a constant heat flux to one side of the duct..
- Run a steady-state heat transfer analysis of the duct.

Model Description:

Below is shown a compact heat exchanger consisting of 5 small ducts which pass the cooling air through them. The model contains both a constant heat flux and constant air flow properties. In this example you will model the behavior of one of the ducts in a steady-state heat transfer analysis.

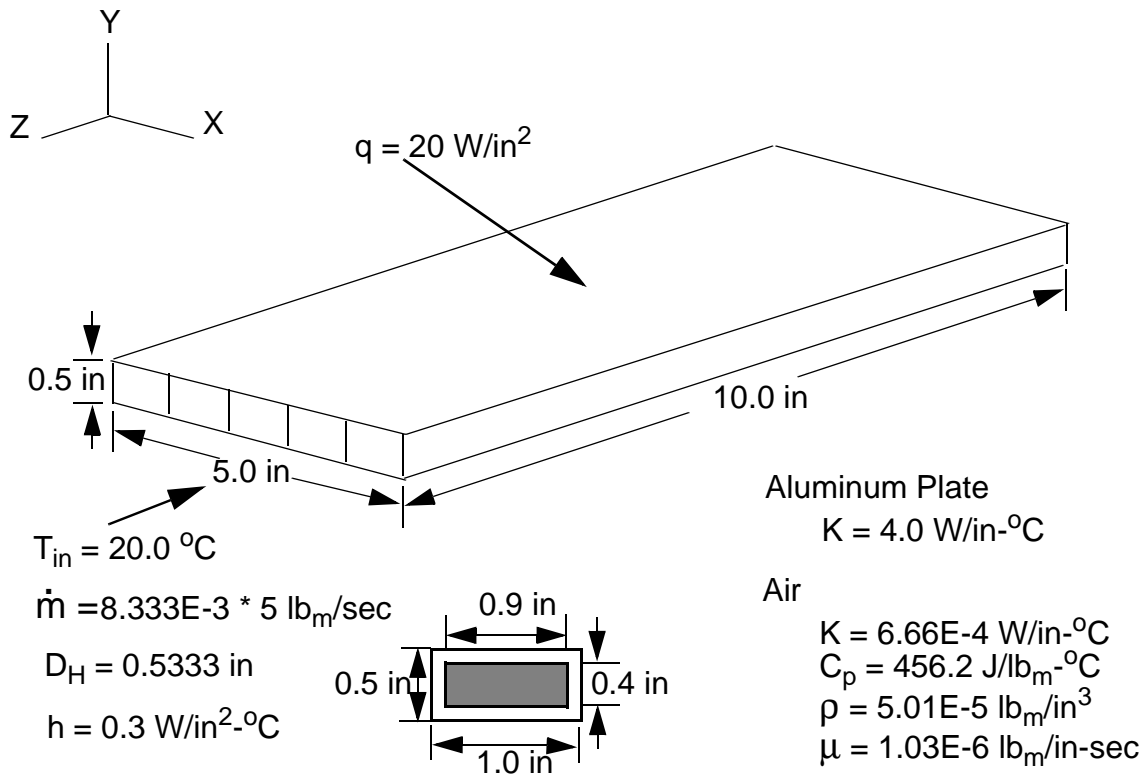

Exercise Procedure:

1. Start up MSC.Nastran for Windows 4.0.2 and begin to create a new model.

Double click on the icon labeled MSC.Nastran for Windows V4.0.2.

On the *Open Model File* form, select **New Model**.

Open Model File:

New Model

2. Create the geometry for the duct.

First, create a surface for one side of the duct.

Geometry/Surface/Corners...

Fill in the table as the following:

X:	Y:	Z:	
0	0	0	OK
1	0	0	OK
1	10	0	OK
0	10	0	OK

Cancel

To fit the display onto the screen, use the Autoscale feature.

View/Autoscale... <Ctrl+A>

Next, copy the surface to create the opposite side of the duct.

Geometry/Copy/Surface...

Select All

OK

OK

	X:	Y:	Z:
<i>Base:</i>	0	0	0

Tip:

X:	Y:	Z:
0	0	0.5

OK

Rotate the model to a dimetric view.

View/Rotate... <F8>

Dimetric

OK

Your model should be like the following:

Figure 3-1: Geometry of the 2 sides of the duct model

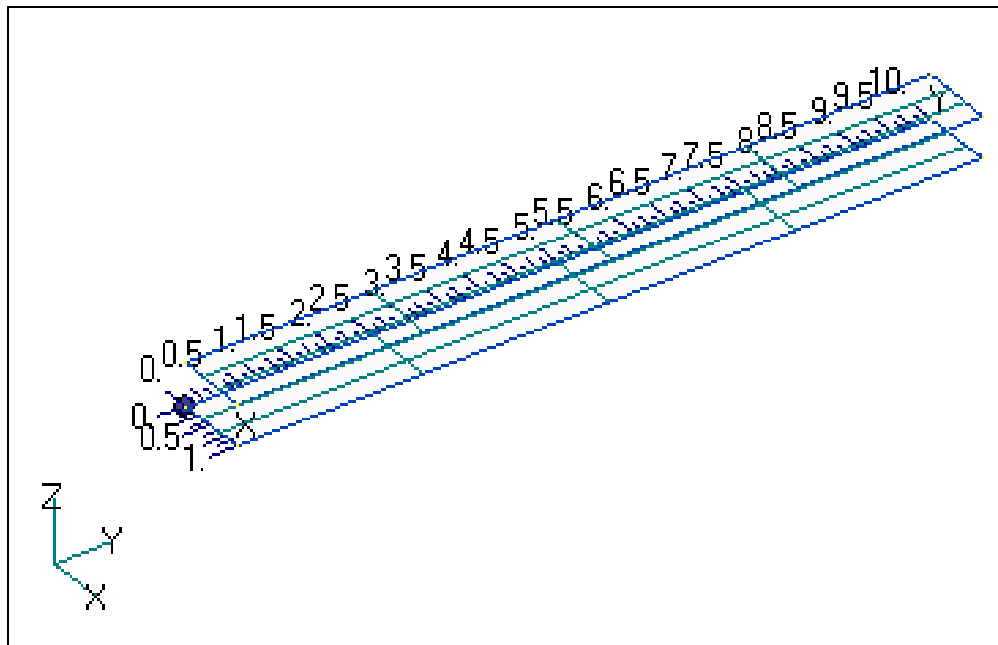

Tools/Workplane... <F2>

Draw Workplane

Done

View/Options... <F6>

● Labels, Entities and Color

Options:

Point

Label Mode:

1..ID

Apply

OK

Create the third side of the duct by connecting corners.

Geometry/Surface/Corners...

Methods^

(select On Point)

Point ID:

20

OK

10

OK

11

OK

19

OK

Cancel

Copy this surface to create the final side of the duct.

Geometry/Copy/Surface...

ID:

4

More

OK

OK

Base:

0

0

0

Tip:

-1.0

0

0

OK

Your model should be like the following:

Figure 3-2: Geometry of the duct model

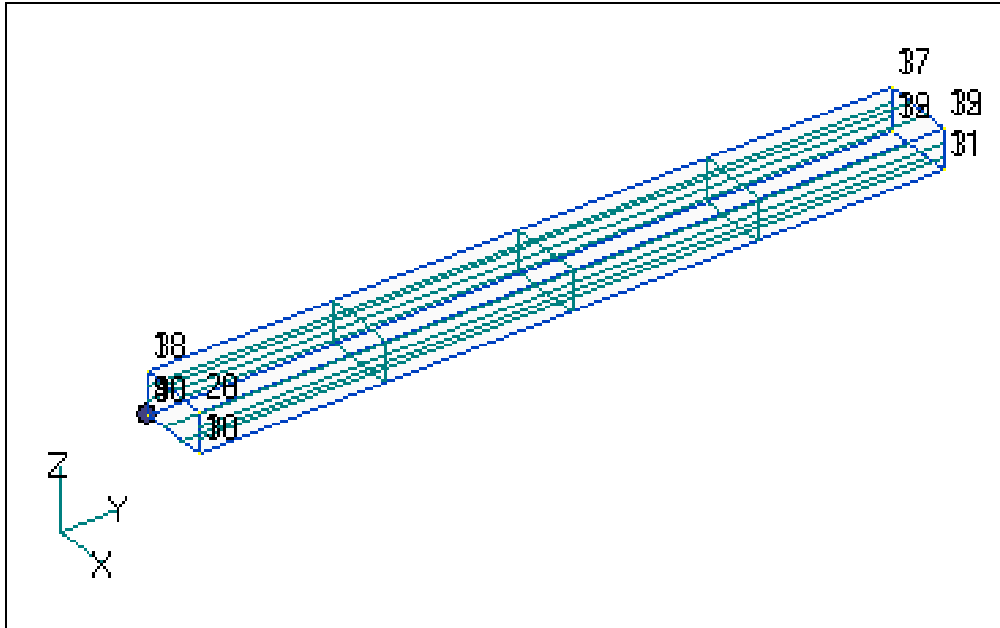

- Set the default size for the mesh.

Mesh/Mesh Control/Default Size...

Size:

- Create a material called **heatsink**.

From the pulldown menu, select **Model/Material**.

Model/Material...

Title:

Conductivity, *k*:

-
5. Create a property called **heatsink** to apply to the members of the duct itself.

From the pulldown menu, select **Model/Property**.

Model/Property...

Title:

To select the material, click on the list icon next to the databox and select **heatsink**.

Material:

Thickness, Tavg or T1:

6. Create the mesh for the duct.

Mesh/Geometry/Surface...

Property:

7. Create a curve to apply the airflow representation to.

First, create two points to define the line.

Geometry/Point...

(select **Locate**)

X:	Y:	Z:	
<input type="text" value="0"/>	<input type="text" value="0"/>	<input type="text" value="1.5"/>	<input type="button" value="OK"/>
<input type="text" value="0"/>	<input type="text" value="10"/>	<input type="text" value="1.5"/>	<input type="button" value="OK"/>

Next, connect the two points with a line.

Geometry/Curve-Line/Points...

From Point:

To Point:

8. Create the mesh for the curve.

Mesh/Geometry/Curve...

(select the newly created curve.)

Line Elements:

 Tube

Title:

Material:

9. Check for coincident nodes and merge them.

Tools/Check/Coincident Nodes...

When asked if you wish to specify an additional range of nodes to merge, select **No**.

Merge Coincident Entities

OK

Turn off all labels.

View/Options... <Ctrl+Q>

Quick Options...

Labels Off

Done

10. Create a body load defining the properties of the fluid flow.

First, a load set must first be created before creating the appropriate model loading.

Model/Load/Set...

Title:

heatsink

OK

Next, create the following body load.

Model/Load/Body...

(next to Thermal options)

Active

Default Temperature:

98

OK

Model/Load/Heat Transfer...

Forced Convection:

Alternate Formulation

Constant Coefficient:

0.023

Reynolds Exponent:

0.8

Prandtl Exponent (into fluid):

0.4

*Prandtl Exponent
(out of fluid):*

0.4

Fluid Conductivity:

6.66e-4

Fluid Specific Heat:

456.2

Fluid Viscosity:

Fluid Density:

11. Create the inlet temperature for the fluid flow.

Model/Load/Nodal...

(select left node on curve - Node 211)

Type:

Temperature:

12. Create the convection loading for the model.

First, create the loading for the duct elements. Assuming the fin surface is 3 times the outside area.

Model/Load/Elemental...

(select on Surface)

(Select the 4 surfaces that represent the duct.)

Type:

Forced Convection

Disable Advection

Flow Rate:

Diameter:

Area Factor:

Next, create the loading for the flow elements.

Methods^

(*select on Curve*)

(*Select the curve that represents fluid flow.*)

OK

Type:

Convection

Forced Convection

Disable Convection

Flow Rate:

.008333

Diameter:

.5333

Temperature:

0

OK

13. Create the heat flux load on one side of the duct.

Methods^

(*select on Surface*)

(*Select the bottom surface of the chart. (surface 1)*)

OK

Type:

Heat Flux

Flux:

20

OK

Face:

1

OK

Cancel

Zoom in to the duct. Check to make sure that the convection markers are all pointing in the same direction. In another words, all the green arrows should be pointing to positive Y direction (in dimetric view).

14. Modify the element normals so the analysis will run correctly.

If some of the arrows are pointing the wrong direction, then the elements which have these arrows will need to be reversed. (This step is optional since all the convection markers are all pointing in the right direction).

Modify/Update Elements/Reverse...

(Select the elements to be reversed.)

More

OK

OK

Methods^

Base Node ID:

Tip Node ID:

OK

● Align First Edge to Vector

(select Nodes)

127 (bottom left node of top surface)

3 (bottom left node of bottom surface)

View/Regenerate...

(or use < Ctrl>+G)

All of the convection arrows should now point in the same direction. Zoom into the model to check the flow direction if it is necessary. All flow should be in the positive **Y** direction.

15. Create the input file and run the analysis.

File/Export/Analysis Model...

Analysis Type:

20..Steady-State Heat Transfer

OK

File Name:

Advection

Write

Run Analysis

OK

When asked if you wish to save the model, respond **Yes**.

Yes

File Name:

fluid

Save

When the MSC.Nastran manager is through running, MSC.Nastran for Windows will be restored on your screen, and the *Message Review* form will appear. To read the messages, you could select **Show Details**. Since the analysis ran smoothly, we will not bother with the details this time.

Continue

16. Remove the thermal loading markers from the screen.

View/Options... <Ctrl+Q>

Quick Options...

All Entities off

Element

Done

OK

17. Create a final temperature distribution contour plot.

View/Select... <F5>

Contour Style:

Contour

Deformed and Contour Data...

Output Set:

1..Case 1 Time 1

Contour:

31..Temperature

OK

Model Style:

Quick Hidden Line

Render

OK

In Figure 3-3, notice how the temperature profile of the duct increases as you traverse the duct, representing the fact that the air removes the most heat at the duct inlet (where the temperature difference is greatest).

Also notice that the elements on the bottom (where the heat flux is applied) have a higher temperature as well.

When done, exit MSC.Nastran for Windows.

File/Save**File/Exit**

This concludes this exercise.

Figure 3-3: Fluid Advection Thermal Analysis on a Duct Model

