

---

## WORKSHOP 14

# *Snapfit Contact*

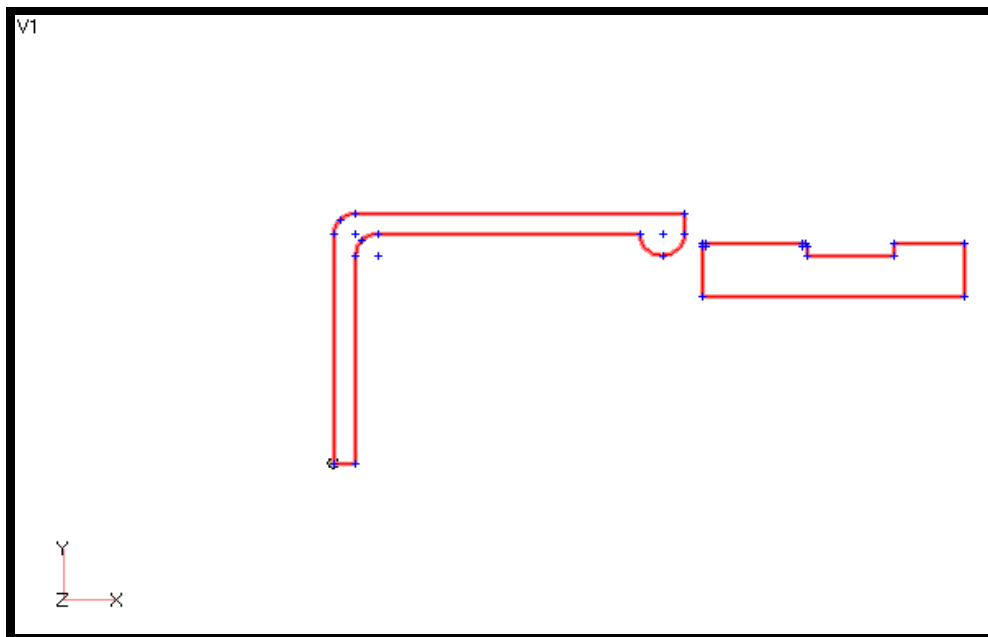

### Objectives:

- Demonstrate the use of snapfit contact
- Define a geometry of the model.
- Apply appropriate loads and boundary conditions.
- Run a nonlinear static analysis.



### Model Description:

A “Snapfit” type of problem is a common type of problem. Finite Element Analysis (FEA) is a useful tool for designing a very common type of system such as a “snapfit” contact problem. FEA assists in calculating the required amount of force to position the part into place. In addition, FEA is able to determine how much one part can overhang the other. Too much overlap results in localized yielding and the part will not sit right in its final position. On the other hand, insufficient overlap will cause the part to be too loose in its final position. As a result, costly prototyping of these systems can be avoided with FEA. The following exercise will demonstrate the modeling of these systems and others that use 2D planar contact.

**Figure 14.1** Geometry of plastic latch and block.

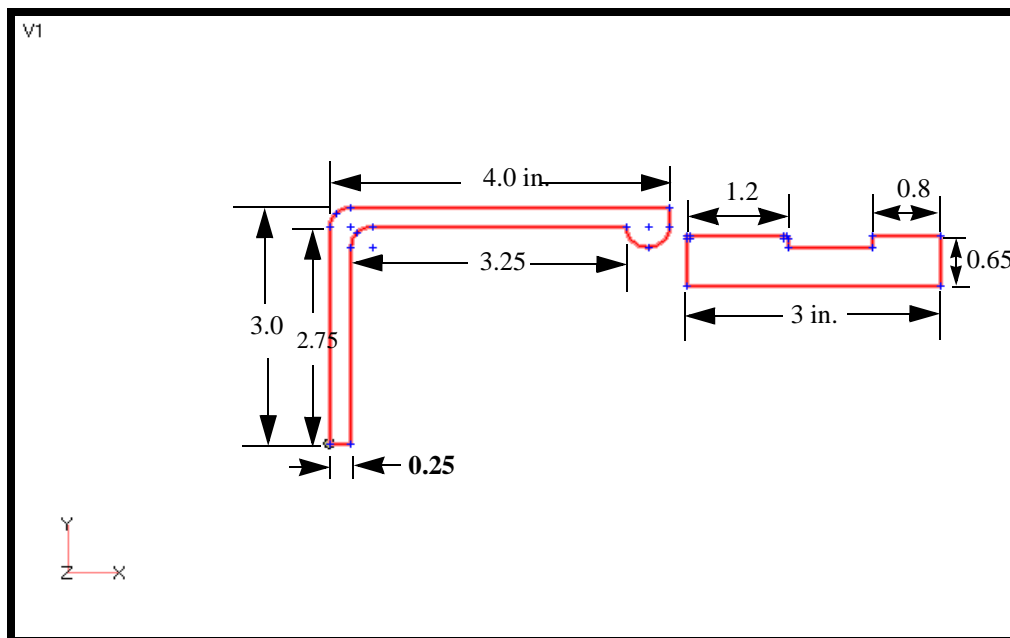

**Table 14.1** Material Properties

<b>Plastic Latch (Acrylic)</b>	<b>Youngs Modulus = 3.5E+5 psi Poisson's Ratio = 0.35</b>
<b>Steel Block</b>	<b>AISI 4340 Steel</b>

---

## Suggested Exercise Steps:

- Create material properties.
- Create the geometry of the plastic latch.
- Create the block that the plastic snaps into.
- Mesh the model
- Create constraints and boundary conditions
- Define the contact between the two parts and create a slide line.
- Submit for analysis.

**Exercise Procedure:**

1. Start up MSC.Nastran for Windows 4.0.2 and begin to create a new model.

Double click on the icon labeled MSC.Nastran for Windows V4.0.2.

On the *Open Model File* form, select **New Model**.

*Open Model File:*

**New Model**

(Optional) For users who wish to remove the default rulers in the work plane model, please do the following:

**View/Options...**

*Category:*

**Tools and View Style**

*Options:*

**Workplane and Rulers**

**Draw Entity**

**OK**

2. Two materials for the model will now be defined.

Note: The plastic part is a medium to high impact acrylic. The block is a rigid structure and any material is fine, as long as it is stiffer than the plastic part. Using steel for the block is an acceptable choice.

**Model/Material...**

*Title:*

**Acrylic**

*Youngs Modulus:*

**350000**

*Poisson's Ratio:*

**0.35**

**OK**

**Load...**

*Library Entry:*

**AISI 4340 Steel**

**OK**

**OK**

**Cancel**

3. Create the model's property, or the type of elements that will be used.

### Model/Property...

#### Elem/Property Type...

Plane Elements:

Plane Strain

Title:

Material:

Property Values/Thicknesses:

Title:

Material:

Property Values/Thicknesses:

4. The geometry for the model must be defined. Create the first geometry of the plastic latch.

### Geometry/Point...

Point 1:

X:	Y:	Z:
<input type="text" value="0"/>	<input type="text" value="0"/>	<input type="text" value="0"/>

Point 2:

X:	Y:	Z:
<input type="text" value="0"/>	<input type="text" value="3"/>	<input type="text" value="0"/>

Point 3:

X:	Y:	Z:
<input type="text" value="4"/>	<input type="text" value="3"/>	<input type="text" value="0"/>

Point 4:

X:	Y:	Z:
<input type="text" value="4"/>	<input type="text" value="2.75"/>	<input type="text" value="0"/>

**OK**

*Point 5:*

X:	Y:	Z:
<b>3.75</b>	<b>2.75</b>	<b>0</b>

**OK**

*Point 6:*

X:	Y:	Z:
<b>3.5</b>	<b>2.75</b>	<b>0</b>

**OK**

*Point 7:*

X:	Y:	Z:
<b>.25</b>	<b>2.75</b>	<b>0</b>

**OK**

*Point 8:*

X:	Y:	Z:
<b>.25</b>	<b>0</b>	<b>0</b>

**OK**

**Cancel**

To fit the display onto the screen, use the Autoscale feature.

**View/Autoscale** (Ctrl-A)

Turn on labels,

**View/Options...** (F6)

**Quick Options...**

**Labels On**

**Done**

**OK**

---

5. Create the lines that connect the points.

**Geometry/Curve - Line/Points...**

(Line 1) From Point:

To Point:

(Line 2) From Point:

To Point:

(Line 3) From Point:

To Point:

(Line 4) From Point:

To Point:

(Line 5) From Point:

To Point:

(Line 6) From Point:

To Point:

Add an arc at the end.

**Geometry/Curve - Arc/Center-Start-End...**

Point ID: <Select point 5> Point 5 is the center point of the arc

Point ID: <Select point 6> Point 6 is the start of the arc

**OK**

Point ID: <Select point 4> Point 4 is the end of the arc

**OK**

**Cancel**

The XY view should appear as follows:

**Figure 14.2** Formation of the plastic latch.

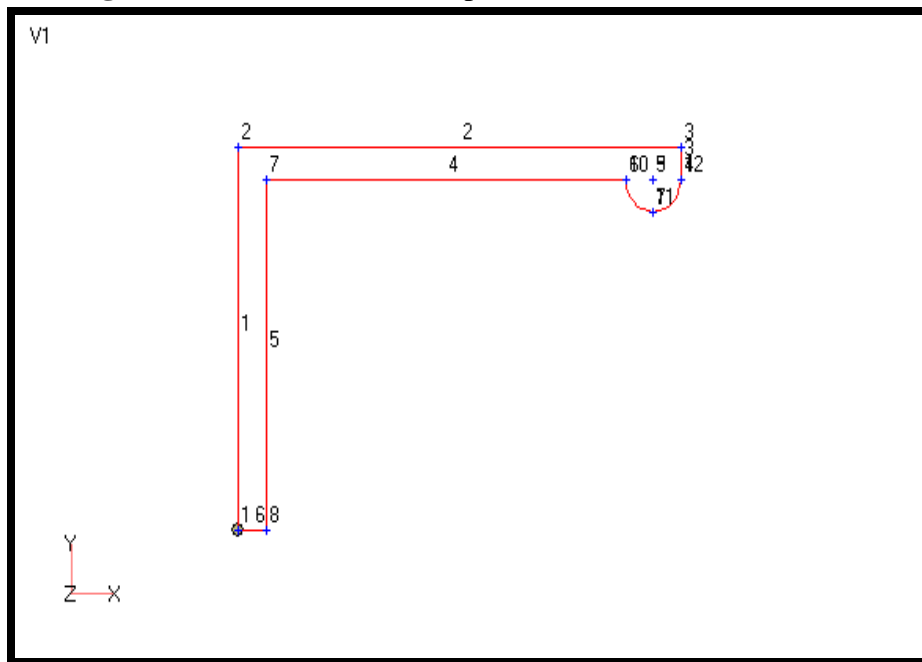

6. Now, add fillets in the upper left corners of the model.

**Modify/Fillet...** (Ctrl-F)

Radius:

Note: Select the curves with the mouse cursor located inside the angle formed by the two lines of fillet. Click in window to the right of Curve 1, then proceed to selecting the curves.

Curve 1 (select inner curve 4):

Curve 2 (select inner curve 5):

**OK**

Curve 1 (select inner curve 1):

Curve 2 (select inner curve 2):

**OK**

**Cancel**

Form a boundary surface.

**Geometry/Boundary Surface...**

**Select All**

**OK**

**Cancel**

The model should now look similar to the image shown

**Figure 14.3** Plastic latch model.

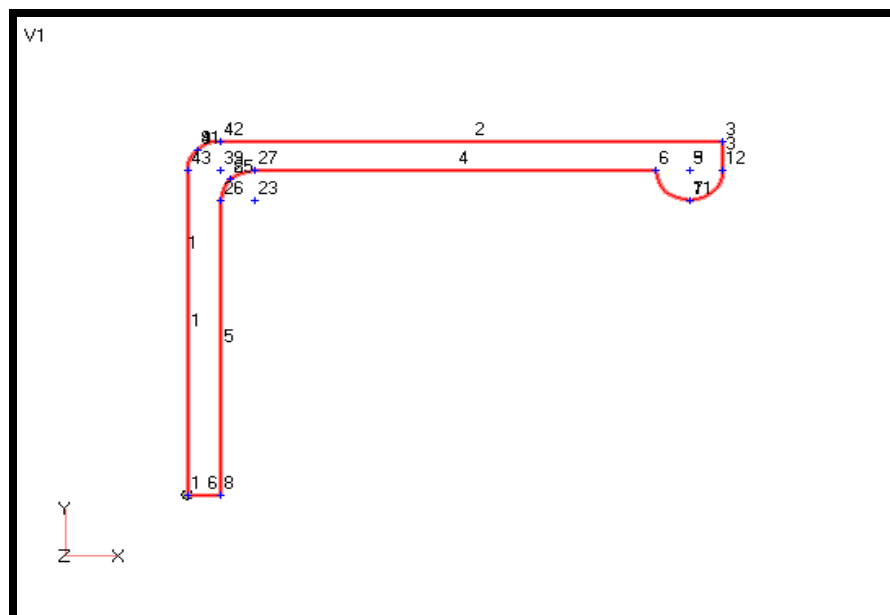

7. Create the block that the plastic snaps into.

**Geometry/Point...**

**Methods ^**

**Locate**

	X:	Y:	Z:
<i>Point ID 45:</i>	<b>4.2</b>	<b>2.65</b>	<b>0</b>
<input type="text" value="OK"/>			
	X:	Y:	Z:
<i>Point ID 46:</i>	<b>5.4</b>	<b>2.65</b>	<b>0</b>
<input type="text" value="OK"/>			
	X:	Y:	Z:
<i>Point ID 47:</i>	<b>5.4</b>	<b>2.5</b>	<b>0</b>
<input type="text" value="OK"/>			
	X:	Y:	Z:
<i>Point ID 48:</i>	<b>6.4</b>	<b>2.5</b>	<b>0</b>
<input type="text" value="OK"/>			
	X:	Y:	Z:
<i>Point ID 49:</i>	<b>6.4</b>	<b>2.65</b>	<b>0</b>
<input type="text" value="OK"/>			
	X:	Y:	Z:
<i>Point ID 50:</i>	<b>7.2</b>	<b>2.65</b>	<b>0</b>
<input type="text" value="OK"/>			
	X:	Y:	Z:
<i>Point ID 51:</i>	<b>7.2</b>	<b>2</b>	<b>0</b>
<input type="text" value="OK"/>			
	X:	Y:	Z:
<i>Point ID 52:</i>	<b>4.2</b>	<b>2</b>	<b>0</b>
<input type="text" value="OK"/>			
<input type="text" value="Cancel"/>			

---

Create the lines that connect the points.

**Geometry/Curve - Line/Points...**

(Line 10) From Point:

To Point:

(Line 11) From Point:

To Point:

(Line 12) From Point:

To Point:

(Line 13) From Point:

To Point:

(Line 14) From Point:

To Point:

(Line 15) From Point:

To Point:

(Line 16) From Point:

To Point:

(Line 17) From Point:

To Point:

Now, add fillets to the corners of the modeled block.

**Modify/Fillet...** (Ctrl-F)

Radius:

Note: Select the curves with the mouse cursor located inside the angle formed by the two lines of fillet. Click in window to the right of Curve 1, then proceed to selecting the curves.

Curve 1(select inner curve 10):

Curve 2(select inner curve 17):

Curve 1(select inner curve 10):

Curve 2(select inner curve 11):

Form a boundary surface that forms the block.

**Geometry/Boundary Surface...**

<Select the curves that form the block using “box pick” method to grab the curves all at once.>

Notes on using the “box pick” method: Place the mouse cursor under the lower right hand corner of the block model. While continuing to hold both the shift key and left mouse button, drag the “rubber band” box to cover the complete geometry of the block. Release the mouse button. Curves “+10,19,1” should be displayed on the dialog screen.

The model should now resemble the image shown

**Figure 14.4** Plastic latch and block

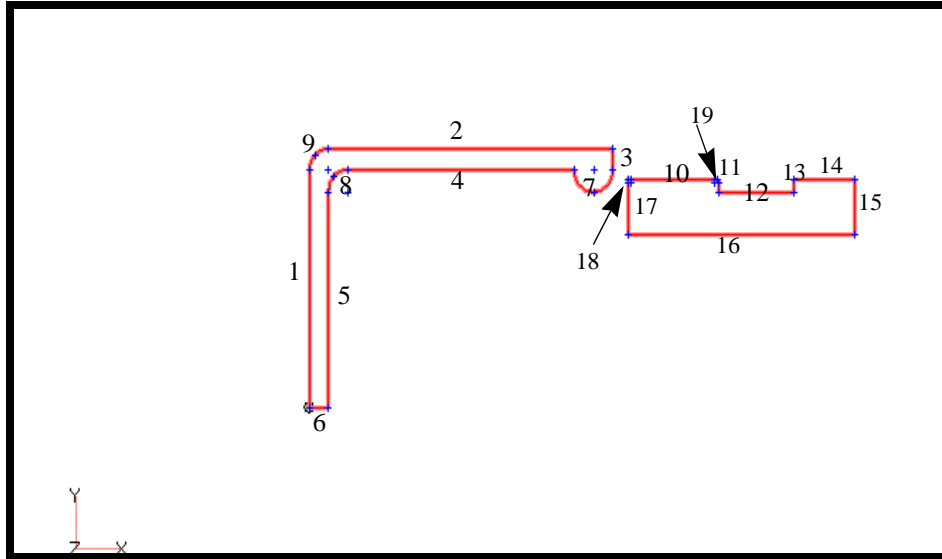

8. Apply a default mesh size to the model.

**Mesh/Mesh Control/Size On Surface...**

Select All

OK

Initial Sizing/Element Size:

0.1

OK

Cancel

9. Refine the mesh for higher accuracy in the areas of interest. This is done by adjusting mesh sizes on the curves. Refer to **Figure 14.4** for locations of curves.

**Mesh/Mesh Control/Size Along Curve...**

Curve ID:

1

OK

Under Mesh Size:

● Number of Elements

25

Under Node Spacing:

● Geometric Bias

Bias Factor:

3

● **Small Elements at End**

**OK**

*Curve ID:*

**OK**

Under Mesh Size:

● **Number of Elements**

Under Node Spacing:

● **Geometric Bias**

*Bias Factor:*

● **Small Elements at Start**

**OK**

*Curve ID:*

**OK**

Under Mesh Size:

● **Number of Elements**

*Node Spacing:* ● **Equal**

**OK**

*Curve ID:*

**OK**

Under Mesh Size:

● **Number of Elements**

*Node Spacing:* ● **Equal**

**OK**

*Curve ID:*

**OK**

Under Mesh Size:

● **Number of Elements**

---

Under Node Spacing:

● **Geometric Bias**

*Bias Factor:*

5

● **Small Elements at Start**

OK

*Curve ID:*

4

OK

Under Mesh Size:

● **Number of Elements**

34

Under Node Spacing:

● **Geometric Bias**

*Bias Factor:*

5

● **Small Elements at Start**

OK

*Curve ID:*

7

OK

Under Mesh Size:

● **Number of Elements**

44

*Node Spacing:*

● **Equal**

OK

*Curve ID:*

3

OK

Under Mesh Size:

● **Number of Elements**

5

*Node Spacing:*

● **Equal**

OK

*Curve ID:*

18

OK

Under Mesh Size:

● **Number of Elements**

*Node Spacing:* ● **Equal**

*Curve ID:*

Under Mesh Size:

● **Number of Elements**

*Node Spacing:* ● **Equal**

*Curve ID:*

Under Mesh Size:

● **Number of Elements**

Under Node Spacing:

● **Geometric Bias**

*Bias Factor:*

● **Small Elements at End**

*Curve ID:*

Under Mesh Size:

● **Number of Elements**

*Node Spacing:* ● **Equal**

*Curve ID:*

Under Mesh Size:

● **Number of Elements**

2

*Node Spacing:*

● **Equal**

**OK**

*Curve ID:*

10

**OK**

Under Mesh Size:

● **Number of Elements**

12

Under Node Spacing:

● **Geometric Bias**

*Bias Factor:*

3

● **Small Elements at Both Ends**

**OK**

**Cancel**

The viewport should display as follows:

**Figure 14.5** Refined mesh of the model.

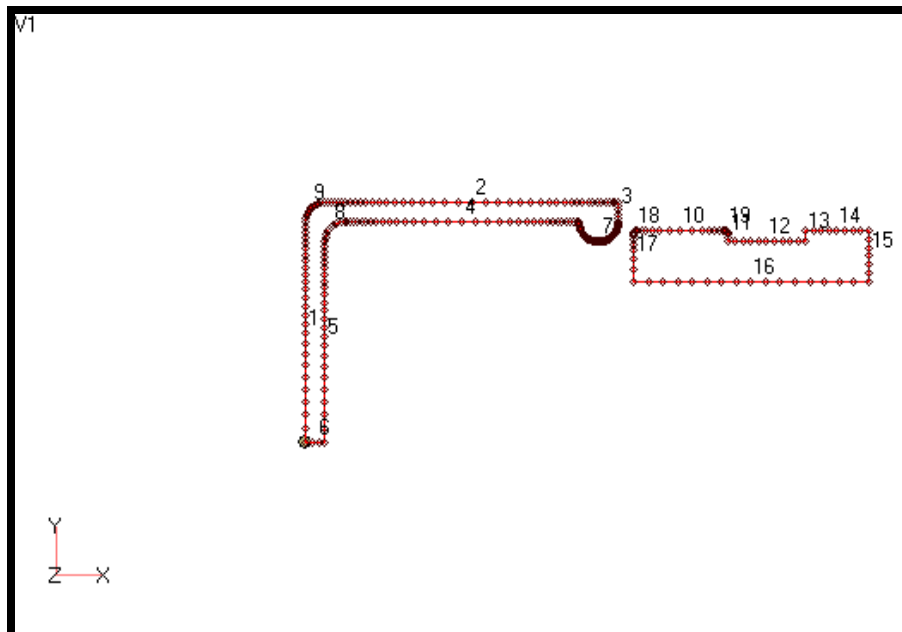

10. The model is ready to be meshed.

**Mesh/Geometry/Surface...**

<Select the plastic latch>

Surface 1

OK

*Property:*

1..Plastic Latch

*Max Element Aspect Ratio:*

4

Quick-Cut boundaries with more than

*Mesh Smoothing:*

Laplacian

*Max Iterations:*

200

*Smooth To:*

0.0001

Constrain the out of plane DOF (since plane strain elements were used).

**Node Param...**

*Permanent Constraints:*

TZ

RX

RY

OK

OK

Similarly, mesh the steel box.

**Mesh/Geometry/Surface...**

<Select the steel box>

Surface 2

OK

*Property:*

2..Steel Box

*Max Element Aspect Ratio:*

4

Quick-Cut boundaries with more than

*Mesh Smoothing:*

Laplacian

---

*Max Iterations:*

**200**

*Smooth To:*

**0.0001**

Constrain the out of plane DOF (since plane strain elements were used).

**Node Param...**

*Permanent Constraints:*

*TZ*

*RX*

*RY*

**OK**

**Elem Param...**

*Color:*

**120**

**OK**

**OK**

Turn off labels, geometry, and node.

**Ctrl-Q**

(Quick Options)

**Labels Off**

**Geometry Off**

**Node**

**Done**

The viewport should resemble as shown.

**Figure 14.6** Meshed model.

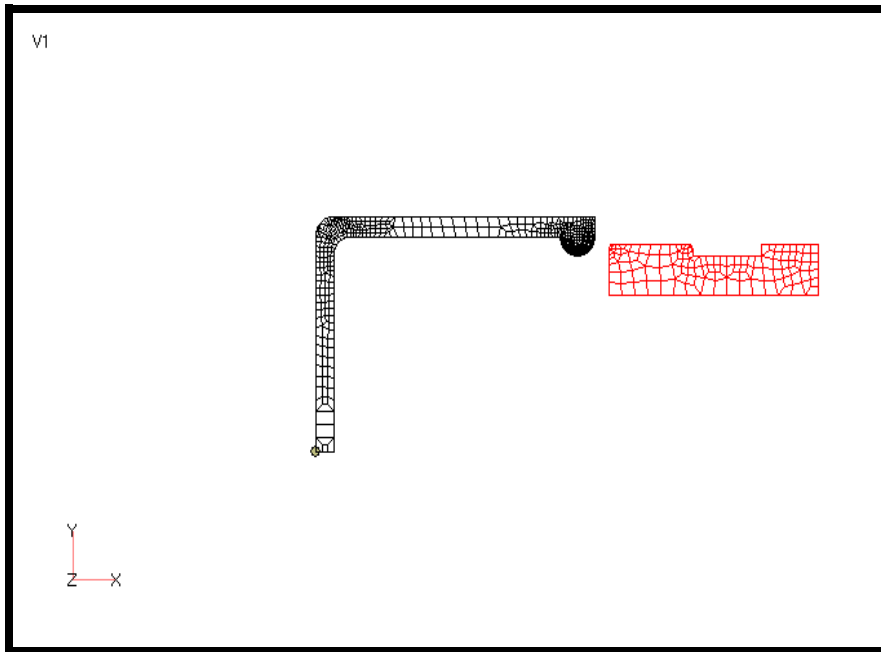

- Define the constraints and boundary conditions.

**Model/Constraint/On Surface...**

*Title:*

**Fixed Block**

**OK**

<Select the block>

**Surface 2**

**OK**

*DOF:*

**Fixed**

**OK**

**Cancel**

- Use an enforced displacement loading condition at the base of the plastic latch to “force” the latch into position.

Note: By using an enforced displacement, the need to know the amount of required force is eliminated. However, knowledge of the final position of the latch is required. In order to use enforced displacement, the nodes that are loaded must be constrained in those same DOF.

**Model/Load/Nodal...**

*Title:*

**Enforced Displacement**

**OK**

<Select the four nodes at the base of the plastic latch>

**Nodes 26, 27, 28, 29**  
(Refer to Fig. 14.7)

**Figure 14.7** Base of the plastic latch.

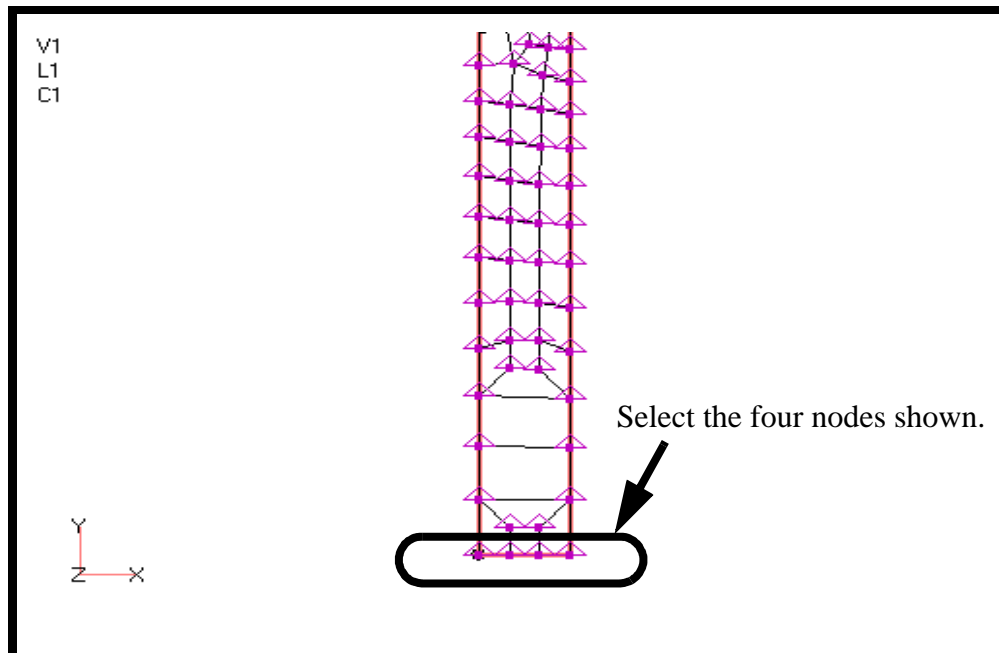

**OK**

(highlight)

**Displacement**

TX

TY

TZ

**OK**

**Cancel**

In order to use enforced displacement, the nodes that are loaded must be constrained in those same DOF.

**Model/Constraint/Nodal...**

(for nodes 26, 27, 28, 29)

TX

The viewport should appear as shown.

**Figure 14.8** Loads and constraints applied to model.

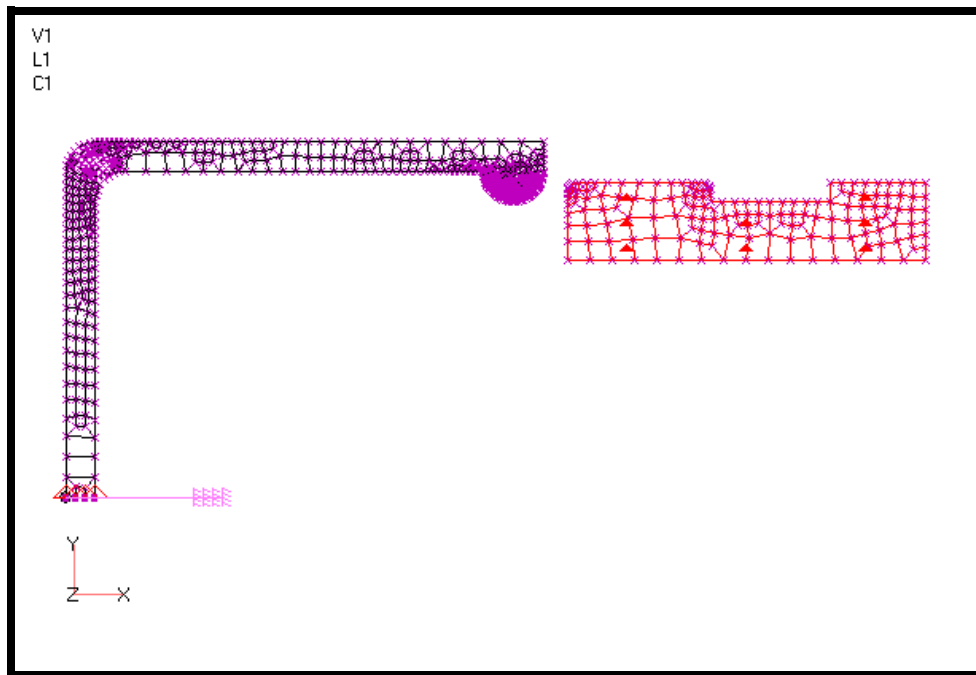

The last step in setting up the loading condition is to set the non-linear options.

**Model/Load/Nonlinear Analysis...**

*Solution Type:*  Static

*Basic / Number of Increments:*

---

*Max Iterations / Step:*

*Output Control / Intermediate:*

*Convergence Tolerances:*  **Displacement**

13. The contact between the two parts must be defined.

**Model/Property...**

*Other Elements:*

*Title:*

*Stiffness Scale Factor:*

*Master Width:*

*Slave Width:*

14. The slide line must now be created.

**Model/Element...**

*Property:*

Note: The nodes must be selected in order without skipping any nodes. The nodes on the master segment should be selected from LEFT to RIGHT. Refer to the diagram in **Figure 14.9** for nodes selection.

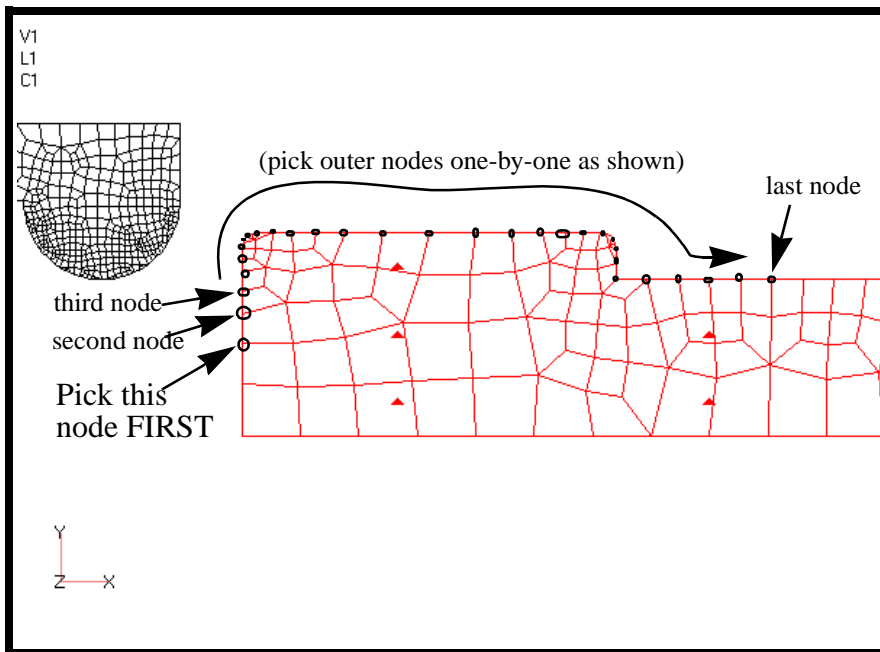
**Figure 14.9** Selection of master nodes.

<Select the master nodes as shown>

**OK**

Now, the slave nodes must be selected. As with the master nodes, the slave nodes must be selected in order without skipping any nodes. The slave nodes must be selected from **RIGHT** to **LEFT**. Refer to the diagram in **Figure 14.10** for nodes selection.

**Slave Nodes**

**Figure 14.10** Selection of slave nodes.

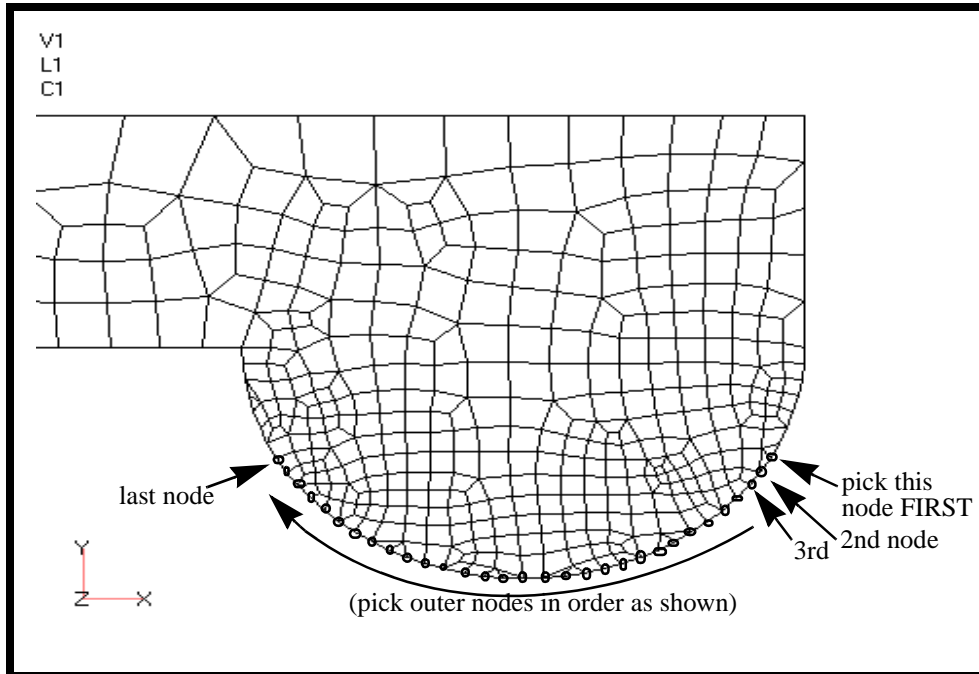

<Select the slave nodes as shown>

**OK**

**OK**

**No**

<Select No to reverse slave and master order>

**Cancel**

The viewport should resemble the following:

**Figure 14.11** Contact between the two parts.

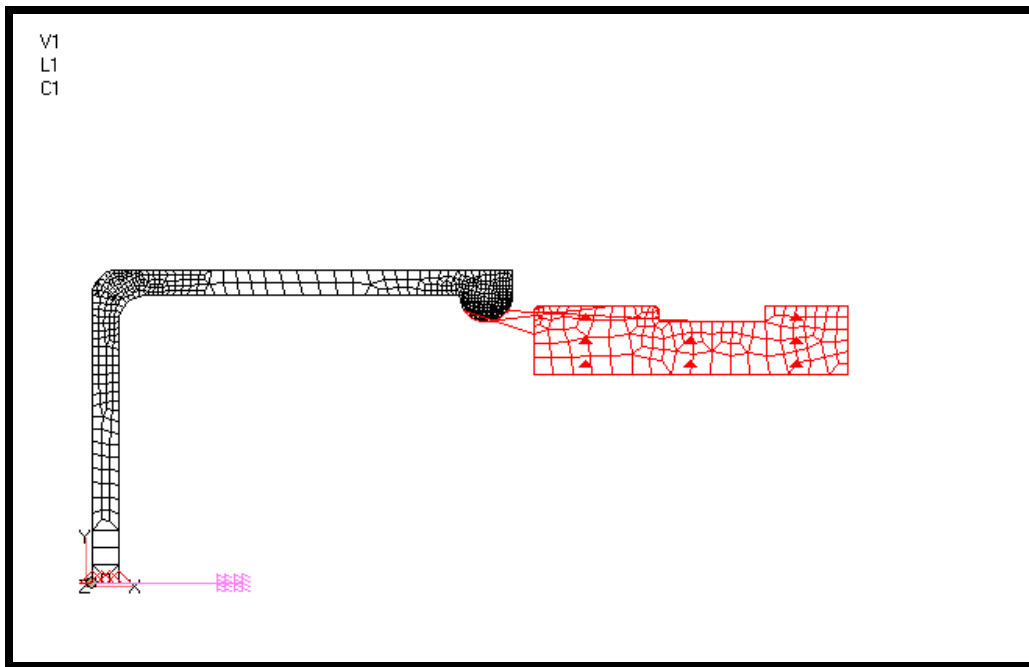

15. Submit the job for analysis.

**File/Export/Analysis Model...**

*Analysis Type:*

**10..Nonlinear Static**

**OK**

Change the directory to C:\temp.

*File Name:*

**prob14**

**Write**

**Run Analysis**

*Output Types:* (pulldown)

**3..All**

**Advanced...**

**OK**

*Output Requests*

**2..Print and PostProcess**

**OK**

---

**OK**

When asked if it is OK to save the model, respond **Yes**.

**Yes**

*File Name:*

**prob14**

**Save**

The *Message Review* form will appear. To read the messages, you could select **Show Details**. Since the analysis ran smoothly, we will not bother with the details this time.

**Continue**

16. Display the deformed plot on the screen.

In order to obtain a better view of the deformation, remove the labels and LBC markers.

**View/Options...**

**Quick Options...**

**Labels Off**

**Coordinate System**

**Load - Force**

**Constraint**

**Done**

**OK**

Plot the deformation of the structure.

**View/Select...**

*Deformed Style:*

**Deform**

*Contour Style:*

**Contour**

**Deformed and Contour Data...**

*Data Selection/Category:*

**1..Displacement**

*Output Set:*

**10..Case 10 Time 0.0009375**

Output Vectors/Deformation:

**1..Total Translation**

Output Vectors/Contour:

**2..T1 Translation**

**OK**

**OK**

In order to see the deformation results accurately, turn off the display scaling of the actual deformation.

**View/Options...**

Category:

**PostProcessing**

Options:

**Deformed Style**

% of Model (Actual)

**OK**

The XY View should appear as follows:

**Figure 14.12**

