

WORKSHOP 12c

Shrink Fit-Modifying Gap Properties

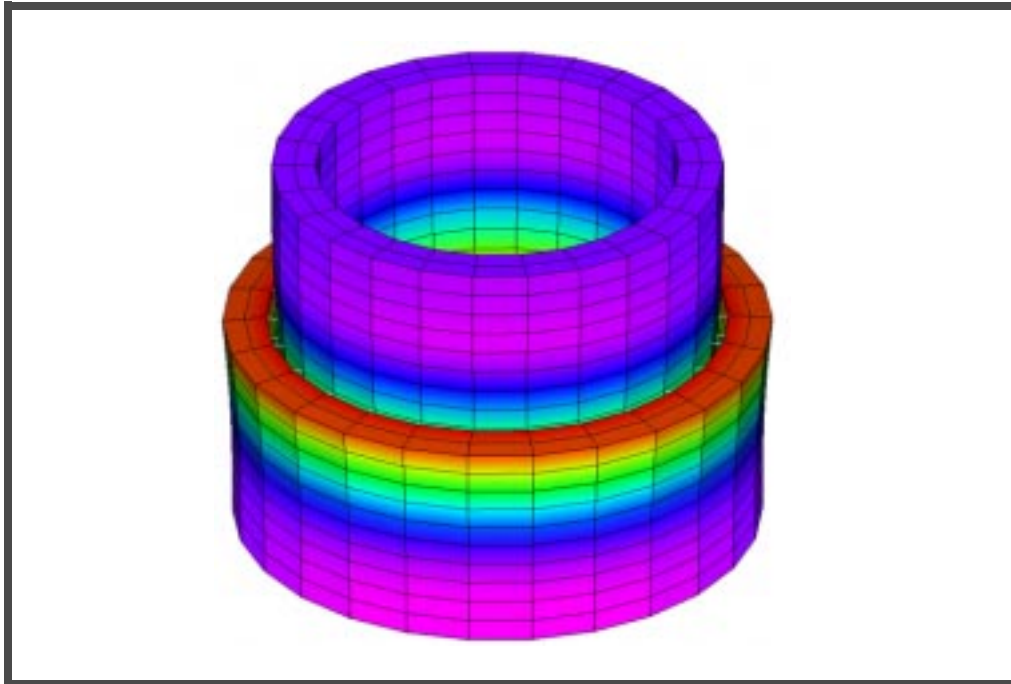

Objectives

- Modify the compression and tension stiffness of the gap properties from the first shrink fit exercise
- Submit the model to MSC.Nastran for analysis.

Model Description:

Generally, gap elements have a high compression stiffness and a low tension stiffness. If the tension stiffness and compression stiffness are reversed, the gap elements will not separate the rings unless the initial gap is also changed.

Suggested Exercise Steps:

1. Open the model from the first exercise, sfit.
2. Rename the exercise sfitc.
3. Modify the gap property.
4. Submit the model to MSC.Nastran for analysis

Exercise Procedure:

1. Start up MSC.Nastran for Windows 4.0.2 and open an existing model.

Double click on the icon labeled MSC.Nastran for Windows V4.0.2.

On the *Open Model File* form, select **Open Model**.

Open Model File:

2. Modify gap property for the gaps.

Modify/Edit/Property...

Input the following Property Values.

Initial Gap:
Compression Stiffness:
Tension Stiffness:

3. Save the model as sfitc.

File/Save As...

File name:

4. Submit the job for analysis.

File/Export/Analysis Model...

Type:

Change the directory to **C:\temp**.

File name:

Write

Run Analysis

OK

When asked if you wish to save the model, respond **Yes**.

Yes

When the MSC.Nastran manager is through running, MSC.Nastran will be restored on your screen, and the *Message Review* form will appear. To read the messages, you could select **Show Details**. Since the analysis ran smoothly, we will not bother with the details this time.

Continue

5. Review the results of the analysis.

View/Select (F5)

Under the *Deformed Style* window, make the following selection:

Deformed Style: **Deform**

Deformed and Contour Data...

Output Set: **2..Case 1 Time 1**

Deformation: **1..Total Translation**

OK

OK

What is the maximum deformation?

Value = _____



<i>Displacement</i>	0.0684
---------------------	--------