

APPENDIX A

Mid-Plane Surface Trimming (Part I)

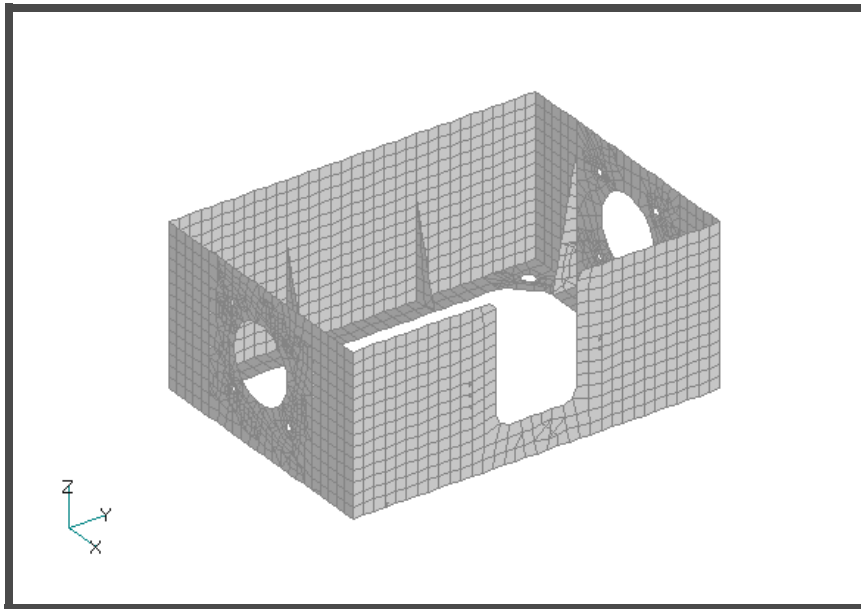

Objectives:

- Automatically extract midplane surfaces.
- Mesh midplane surfaces.

Model Description:

The Parasolid model below can be solid meshed or surface meshed. However, using a surface mesh (2D elements) for analysis is advantageous whenever possible. It decreases the analysis run time as well as conserves system resources.

In order to obtain a surface mesh, we must extract surface geometry at the midplane of the solids. This workshop will demonstrate how to extract midsurfaces from the solid model by using Midsurface/Automatic. This method will automatically extract midsurfaces from the model as well as edit and cleanup the final surface geometry model (some manual editing of the geometry will be required to get an accurate representation of the model). Once we have the surface model, we can obtain a 2D element mesh.

Figure A.1

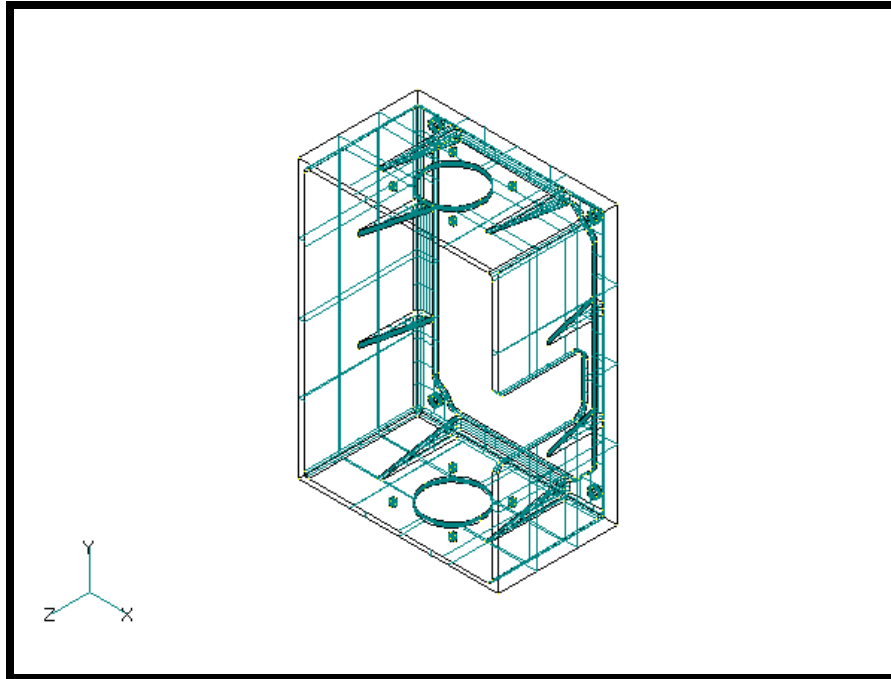

Table A.1- Model Properties

Youngs Modulus:	10E+06 lbs/in²
Poisson's Ratio:	0.3

Suggested Exercise Steps:

- Import the parasolid file **MPexam.x_t**.
- Check the thickness of the part using the **Tools/Distance** command.
- Create a material, **mat_1**.
- Create a new property called **plate**.
- Extract midplane surfaces from the solid using **Automatic Add** command.
- Delete extra surfaces that were created above each wedge.
- Specify a mesh size on the surfaces by accepting the default element size.
- Mesh the midplane surfaces.
- In **View/Options** turn off all entities except for Element.
- Change View Style to Solid.

Exercise Procedure:

1. Start up MSC.Nastran for Windows V4.0 and begin to create a new model.

Double click on the icon labeled **MSC.Nastran for Windows V4.0**.

On the *Open Model File* form, select **New Model**.

Open Model File:

New Model

2. This exercise should be performed with the **Advanced Geometry-Parasolid Engine** turned on.

Tools/Advanced Geometry...

● **Advanced Geometry-Parasolid**

OK

3. First import the parasolid file.

File/Import/Geometry...

Go to the following directory: C:\Mscn4w40\Examples

File name:

MPexam.x_t

Open

OK

4. Rotate to an isometric view by selecting **View/Rotate** or **F8**.

View/Rotate... <F8>

Isometric

OK

Turn off the workplane.

Tools/Workplane... (F2)

Draw Workplane

Done

View/Regenerate... <Ctrl+G>

5. Check the thickness of the part.

Zoom into a corner section of the model. First rotate the part in order to get a better view of one of its edges. Select the **Dynamic Rotate** button for this.



Now use the Zoom button to zoom into area shown below.



Figure A.2

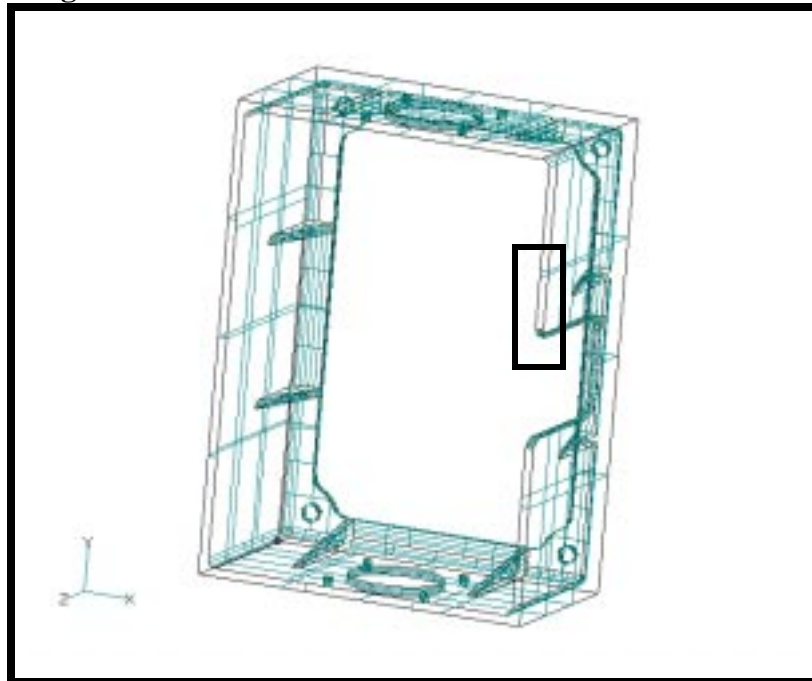

Tools/Distance...

Methods ^

On Point

Click from point 5 to 7 (refer to the following diagram).

Point ID:

5

OK

Point ID:

7

OK

A window will appear indicating that the thickness of the model is 4.92125.

Figure A.3

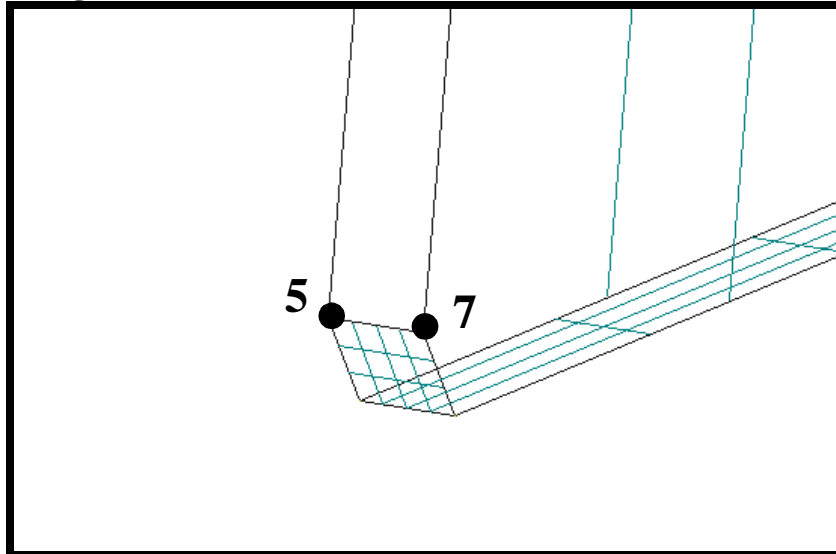

OK

Cancel

6. Create a material called **mat_1**.

From the pulldown menu, select **Model/Material**.

Model/Material...

<i>ID:</i>	1
<i>Title:</i>	mat_1
<i>Youngs Modulus:</i>	10E6
<i>Poisson's Ratio:</i>	0.3

OK

Cancel

7. Create a new property called **plate**.

From the pulldown menu, select **Model/Property**.

Model/Property...

ID:

1

Title:

plate

Elem/Property Type...

Plane Elements:

Plate

OK

To select the material, click on the List icon next to the databox and select **mat_1**.

Material:

1..mat_1

Thicknesses, Tavg or T1:

4.92125

OK

Cancel

Make the geometry fit within the window.

View/Autoscale <Ctrl+A>

8. Create a 2D model from the 3D geometry.

At this point, you can mesh the solid geometry with tetrahedral solid elements. However, to save time and disk space this model can be better idealized by a 2D mesh. To do this, extract midplane surfaces from the solid.

First, create a group to put the new midsurface into.

Group/Set...

Title:

midsurface

OK

Now, set the **Automatic Add** to the **Active** group to automatically add all entities created from this point on to the active group (midsurface).

Group/Operations/Automatic Add...

Active

Next, extract the midsurfaces from the solid model.

Geometry/Midsurface/Automatic...

Enter Target Thickness:

By entering a target thickness of 5, you will have created a midplane surface between any two surfaces that are at or below this distance from each other.

Finally, view the extracted midplane surfaces by posting the Active Group (midsurface).

View/Select... <F5>

Group:

● **Active**

Figure A.4

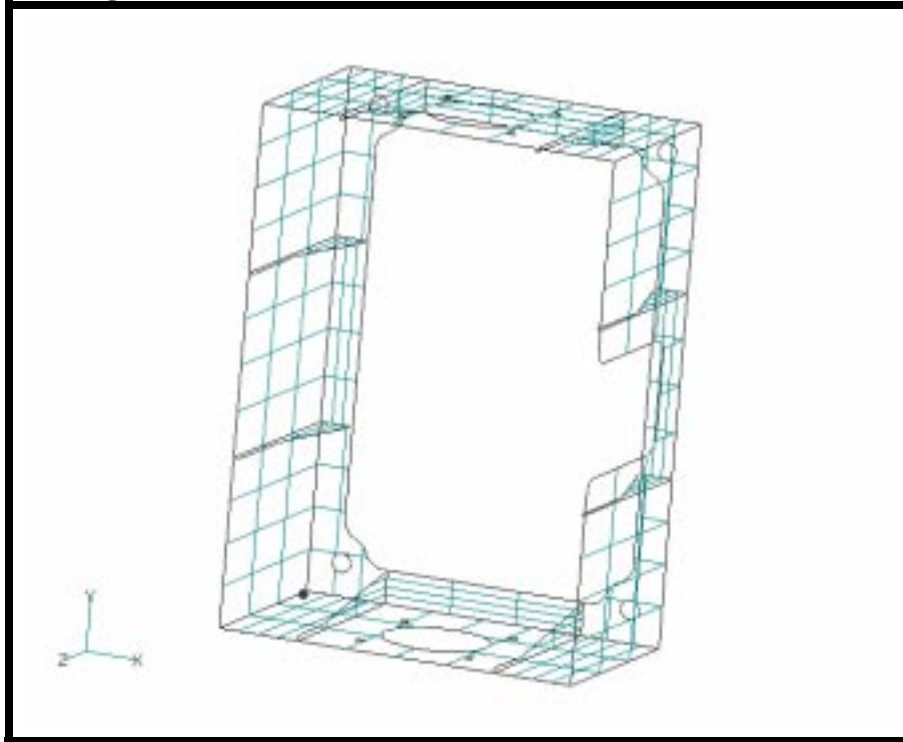

9. Notice that there are extra surfaces or slivers located above each support wedge. These were created by the extraction since the distance between the vertical surface of the wedge and the outer face of the box was within the *Target Thickness*. We must edit some of these features from the surface model.

Reposition the model.

View/Autoscale <Ctrl+A>

View/Rotate... <F8>

Dimetric

OK

Figure A.5

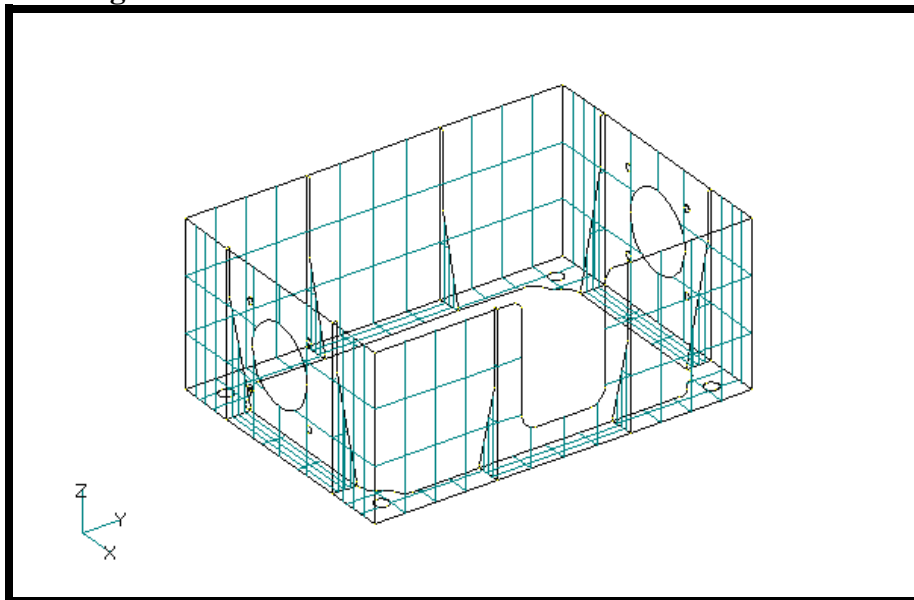

Geometry/Midsurface/Trim with Curve...

Select, one at a time, the 8 surfaces that currently represent the support wedges. For example, select the surface below (**Surface 140**).

Figure A.6

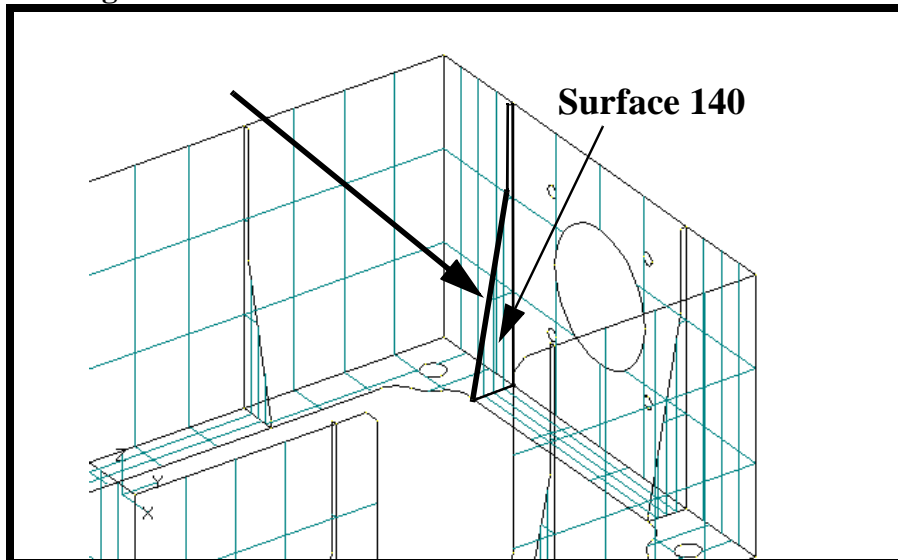

ID:

140

OK

Select on the surface's diagonal curve (**Curve 400**).

OK

Repeat the process for the other 7 surfaces (wedges).

Surface	Curve
209	412
205	406
193	386
189	380
197	413
201	420
137	394

Cancel

Delete the small sliver surfaces that are left above the wedges after you make the edits.

Delete/Geometry/Surface...

Select the small surfaces shown in Figure A.7 on the following page.

Figure A.7

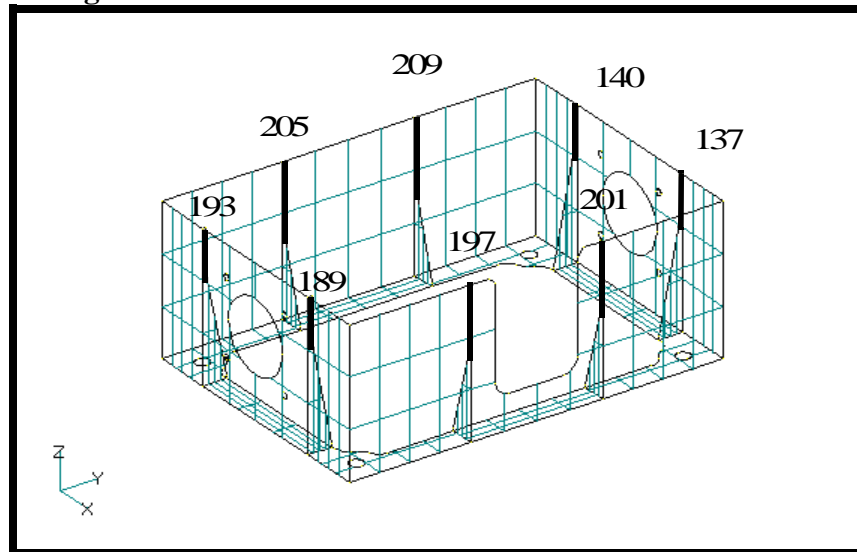

OK

When asked, “OK to Delete 8 Selected Surface(s)?,” select Yes.

Yes

10. Break the surfaces at the intersection between the wall and the support wedges so that the mesh will match.

Geometry/Midsurface/Intersect...

Group:

1..midsurface

OK

11. Specify mesh seeding.

Mesh/Mesh Control/Size on Surface...

Group:

1..midsurface

OK

Accept the default values.

OK

Cancel

12. Mesh the surfaces in the midsurface group.

Mesh/Geometry/Surface...

Group:

1..midsurface

OK

Property:

1..plate

Element Shape:

Quads

OK

Either select the **Quick Options** button or **CTRL+Q**:

Quick Options... <Ctrl+Q>

All Entities Off

Draw:

Element

Done

Select the View Style icon:



(highlight)

Solid

Figure A.8

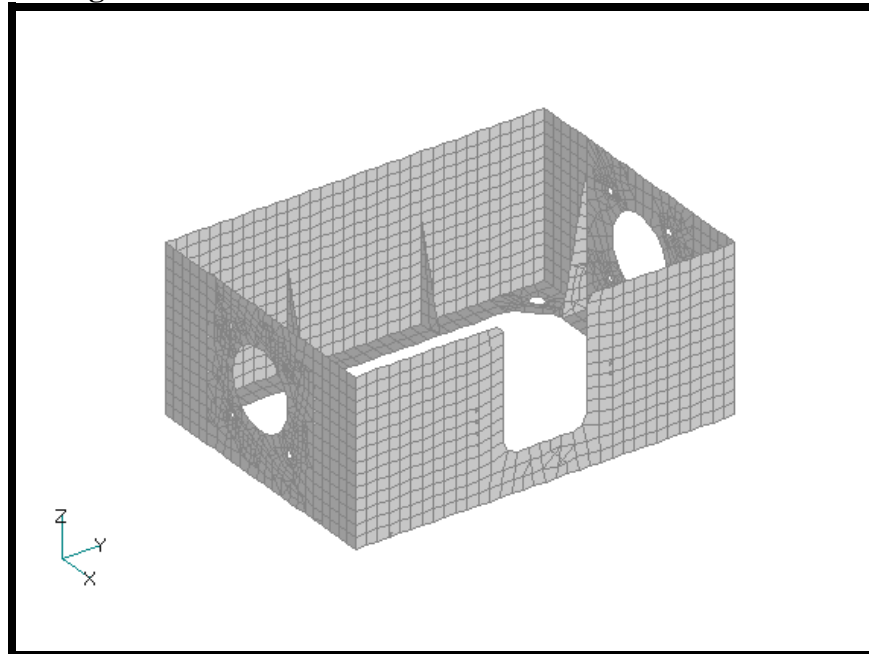

13. Finally, save the file.

File/Save As...

File name:

Midsurface2.mod

This concludes this exercise.

File/Exit

