

WORKSHOP 32

Rigid Element Analysis with RBE2 and CONM2

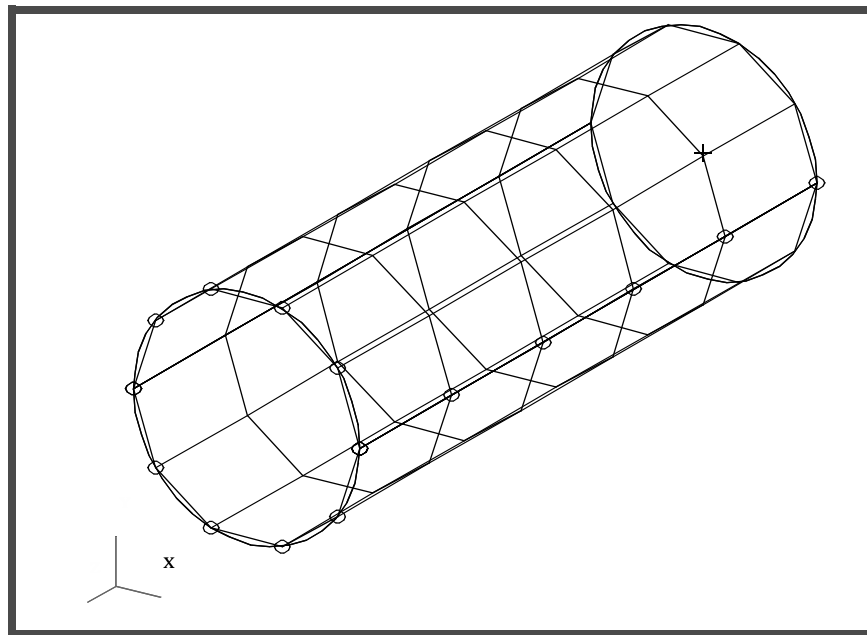

Objectives:

- Create a geometric representation of a tube.
- Use the geometry model to define an analysis model comprised of plate elements.
- Idealize a rigid end using RBE2 elements.
- Define a concentrated mass to represent the weight of the rigid enclosure (CONM2).
- Run an MSC.Nastran linear static analysis.
- View analysis results.

Model Description:

The goal of this example is to maintain a circular cross section at the rigid end of the tube, (using a RBE2 element), while applying a gravitational force of 2.7g in the z-direction.

Additionally, a concentrated mass needs to be defined to represent the weight of the rigid enclosure. It is very important to account for all the weight contribution since inertial loading is used in this problem.

Below is a finite element representation of the tube. One end of the tube is considered rigid, and the other end is fixed in all translational and rotational degrees of freedom. Table 36.1 contains all the necessary parameters to construct the input file.

Figure 32.1

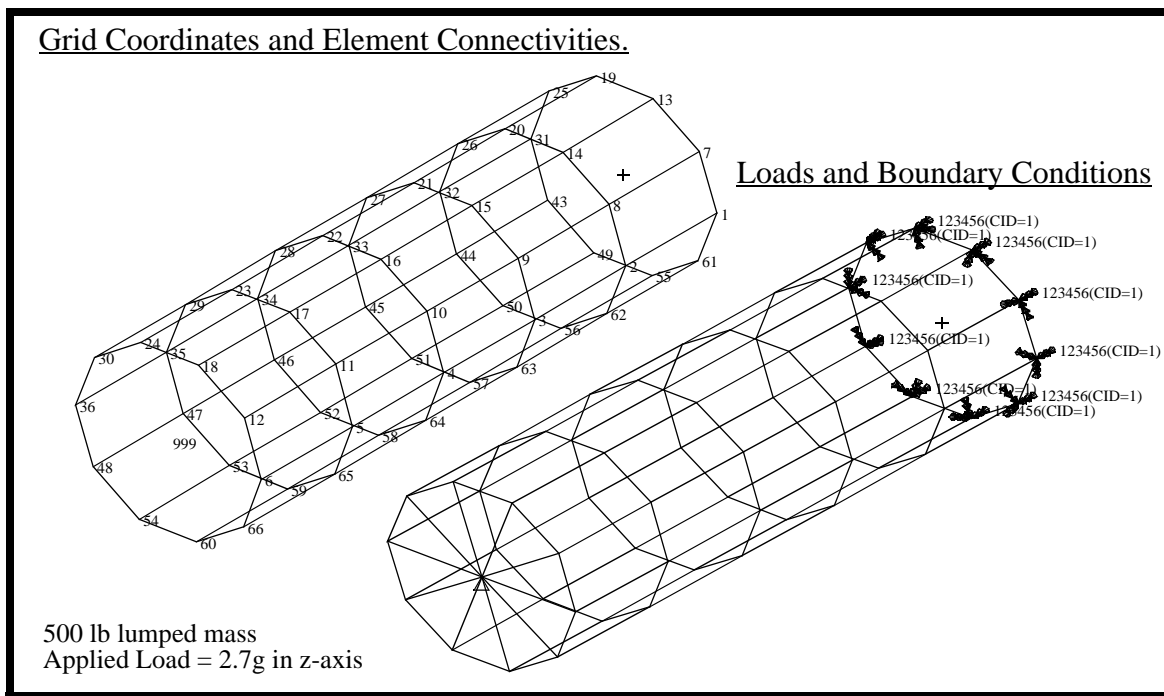

Table 32.1 - Model Properties

| | |
|-------------------------|----------------------------------|
| Radius: | 15 in |
| Thickness: | 0.125 in |
| Length: | 90 in |
| Youngs Modulus: | 10E+06 lbs/in² |
| Poisson's Ratio: | 0.3 |
| Density: | 0.101 lbs/in³ |

Exercise Procedure:

1. Start up MSC.Nastran for Windows 4.0 and begin to create a new model.

Double click on the icon labeled **MSC.Nastran for Windows V4.0**.

On the *Open Model File* form, select **New Model**.

Open Model File:

New Model

2. Create a material called **mat_1**.

From the pulldown menu, select **Model/Material**.

Model/Material...

Title:

mat_1

Youngs Modulus:

10E6

Poisson's Ratio:

0.3

Mass Density:

0.101

OK

Cancel

NOTE: Mass density is important because in this exercise, a gravitational load is going to be applied. Be aware of units!!!

3. Create a property called **tube** to apply to the members of the tube itself.

From the pulldown menu, select **Model/Property**.

Model/Property...

Title:

tube

To select the material, click on the list icon next to the databox and select **mat_1**.

Material:

1..mat_1

Thicknesses, Tavg or T1:

0.125

OK

Cancel

4. Create the MSC.Nastran geometry for the tube.

First, create a cylindrical coordinate system.

Model/Coord Sys...

ID:

Title:

Method: XY Locate

Type: Cylindrical

OK

Define Coordinate System Origin.

X: Y: Z: **OK**

Define Location on CSys X-Axis.

X: Y: Z: **OK**

Define Location in CSys XY-Plane.

X: Y: Z: **OK**

Cancel

5. Now create the surface of the tube.

Tools/Advanced Geometry...

Geometry Engine:

● **Standard**

OK

Geometry/Surface/Cylinder...

| | X: | Y: | Z: |
|--------------|--------------------------------|--------------------------------|---------------------------------|
| <i>Base:</i> | <input type="text" value="0"/> | <input type="text" value="0"/> | <input type="text" value="0"/> |
| <i>Tip:</i> | <input type="text" value="0"/> | <input type="text" value="0"/> | <input type="text" value="90"/> |

On the CSys drop down menu, select **tube_coordinate**.

CSys: (pulldown)

3..tube_coordinate

OK

Locate direction to the start of the surface.

| | X: | Y: | Z: |
|--------------|--------------------------------|--------------------------------|--------------------------------|
| <i>Base:</i> | <input type="text" value="0"/> | <input type="text" value="0"/> | <input type="text" value="0"/> |
| <i>Tip:</i> | <input type="text" value="1"/> | <input type="text" value="0"/> | <input type="text" value="0"/> |

OK

Now, input the radii of the cylinder.

Radii/Bottom Outer:

OK

Cancel

6. Use **Autoscale** and **Rotate** to better view model.

View/Autoscale <Ctrl+A>

View/Rotate... <F8>

Isometric

OK

7. Now define the mesh size on the tube.

Mesh/Mesh Control/Mapped Divisions on Surface...

| | | | |
|---------------------------|----------|----------|-----------|
| Select All | | | |
| OK | | | |
| | <i>s</i> | <i>t</i> | |
| <i>Number of Element:</i> | 11 | 5 | |
| <i>Bias:</i> | 1. | 1. | OK |
| Cancel | | | |

8. Finally, create the finite element entities.

Mesh/Geometry/Surface...

| | |
|----------------------------------|--------------------|
| Select All | |
| OK | |
| <i>Property:</i> | 1..tube |
| Node Param... | |
| <i>Output Coordinate System:</i> | 3..tube_coordinate |
| OK | |
| OK | |

9. Merge coincident nodes

Tools/Check/Coincident Nodes...

| |
|-------------------|
| Select All |
| OK |

OK to Specify Additional Range of Nodes to Merge?

Options:

Merge Coincident Entities

10. Now define the node where the concentrated mass will be applied.

Model/Node...

R: T: Z:

ID:

11. Now define the concentrated mass property.

Model/Property...

Title:

Elem/Property Type...

Other Elements: Mass

In the *Property Values* box, specify the mass.

Mass, M or Mx:

12. Now apply the concentrated mass to the model at Node 999.

Model/Element...

ID:

Property:

Node:

13. Now, idealize a rigid end using an RBE2 element.

Model/Element...

Other Elements: Rigid

Under the *Independent* box, select Node 999 and the degrees of freedom.

Node:

DOF: TX RX
 TY RY
 TZ RZ

Under the *Dependent* box, select all the nodes along the free edge.

< Select end curve where
CONM2 is located >

Cancel

Check the *messages* box that “Element 1000” was created.

14. Create the nodal constraint.

Before creating the appropriate constraints, a constraint set needs to be created. Do so by performing the following.

Model/Constraint/Set...

Title:

constraint

OK

Now define the relevant constraint for the right free edge.

Model/Constraint/Nodal...

Method^

On Curve

< *Select the other end curve* >

OK

Fixed

OK

Cancel

Check the *messages* box that 10 Nodes were selected.

15. Create the loading condition.

Model/Load/Set...

Title:

inertia

OK

Now define the inertia load.

Model/Load/Body...

To input Translation/Gravity, check on *Active* next to *Acceleration* box. It is the first *Active* box from the top.

Active

Translation/Gravity:
(length/time/time)

X:

Y:

Z:

0

0

1043.28

OK

This value is calculated by taking 2.7 x gravity. Gravity is 386.4 in/s² for this model. Again, be aware of units!!!

16. Now create and submit the analysis file.

File/Export/Analysis Model...

Analysis Format/Type:

1..Static

OK

Change the directory to **C:\Temp**.

File Name:

rigid

Write

Additional Info:

Run Analysis

Advanced...

Problem ID:

Rigid Element Analysis

OK

OK

Under *PARAM*, enter the following:

WTMASS

0.00259

OK

This value is necessary because we have entered the “mass” in this model as weight units. 0.00259 is 1/386.4, so all this parameter does is divide the mass matrix by gravity. By doing so, the mass matrix will truly have mass units.

When asked if you wish to save the model, respond **Yes**.

Yes

File Name:

rigid

Save

When the MSC.Nastran manager is through running, MSC.Nastran will be restored on your screen, and the *Message Review* form will appear. To read the messages, you could select **Show Details**. Since the analysis ran successfully, we will not bother with the details this time.

Continue

17. Consider the results.

List/Output/Query...

Output Set:

1..MSC/Nastran Case 1

Category:

1..Displacement

Entity:

Node

11

More

15

More

52

OK

NOTE: You may want to expand the message box in order to view the results.

Answer the following questions using the results. The answer is listed at the end of the exercise.

What is the displacement for Nodes 11, 15 and 52?

T3 = _____

This concludes this exercise.

File/Save

File/Exit

| | |
|-------|-------------|
| Nodes | 13 |
| II: | 0. |
| IS: | 0.00240996 |
| SZ: | 0.000940049 |

